

7<9: TIP

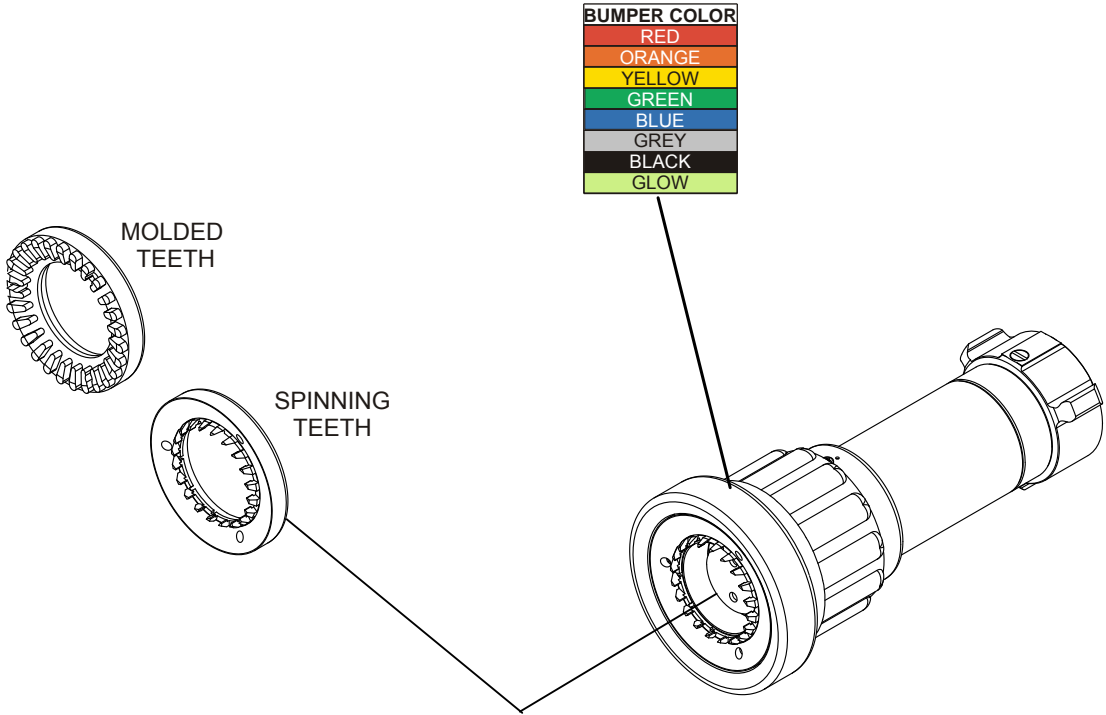

FIGURES DEPICT GENERAL PRODUCT TYPES ONLY AND ARE NOT INTENDED TO BE INCLUSIVE OF ALL PRODUCT FEATURES.

	ELKHART BRASS MFG. CO., INC. ELKHART, INDIANA	
	THIS DRAWING CONTAINS INFORMATION THAT IS PROPRIETARY TO ELKHART BRASS MFG. CO., INC. AND MAY NOT BE USED TO PRODUCE ANY PARTS, ASSEMBLIES OR PRODUCTS DESCRIBED HEREIN WITHOUT EXPRESS WRITTEN PERMISSION.	
CHIEF PAGE 1 OF 4 06/2008	CONFIGURATION DRAWING	

7<9: NOZZLE

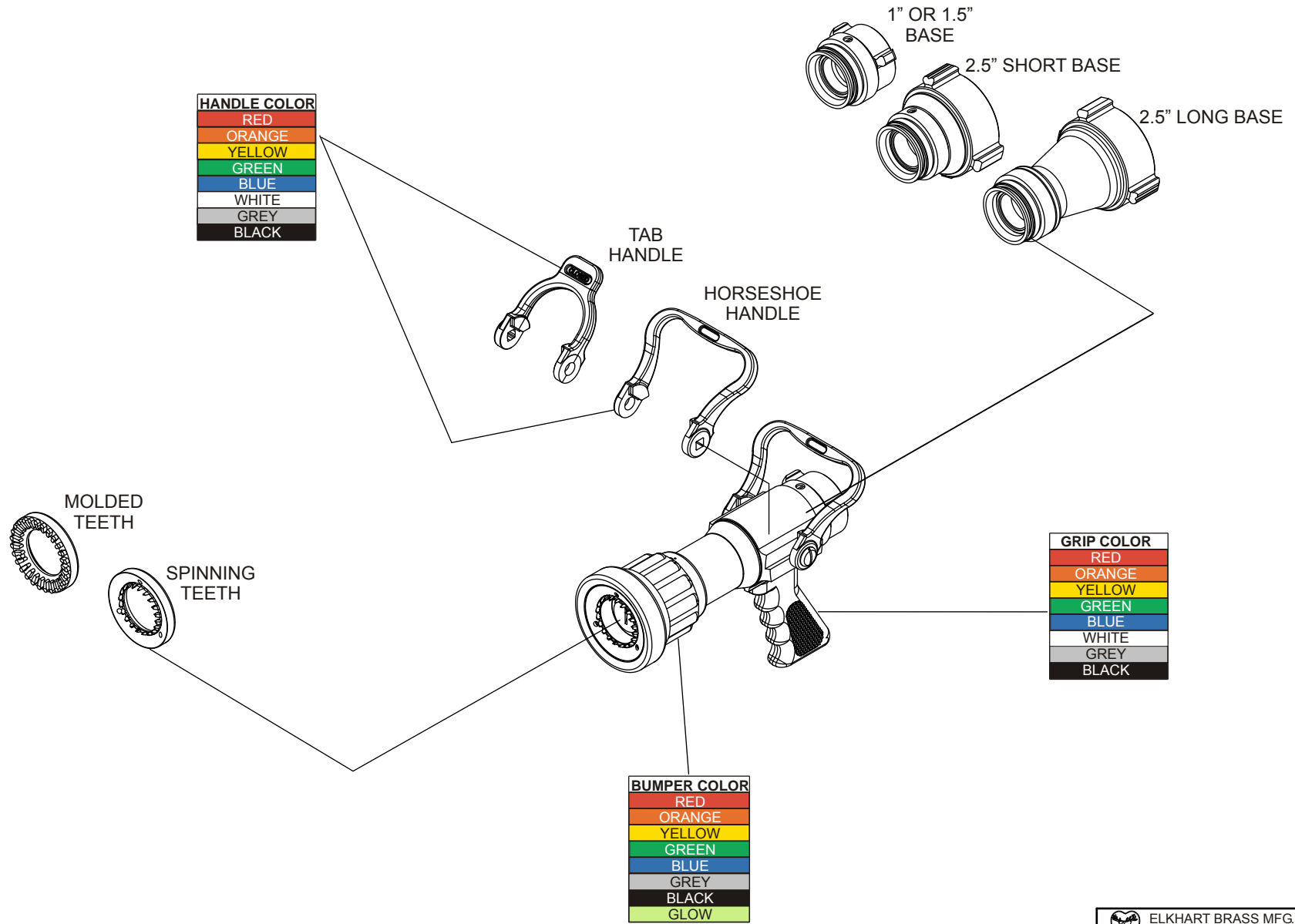

FIGURES DEPICT GENERAL PRODUCT TYPES ONLY AND ARE NOT INTENDED TO BE INCLUSIVE OF ALL PRODUCT FEATURES.

 ELKHART BRASS MFG. CO., INC. ELKHART, INDIANA	
THIS DRAWING CONTAINS INFORMATION THAT IS PROPRIETARY TO ELKHART BRASS MFG. CO., INC. AND MAY NOT BE USED TO PRODUCE ANY PARTS, ASSEMBLIES OR PRODUCTS DESCRIBED HEREIN WITHOUT EXPRESS WRITTEN PERMISSION.	
CHIEF PAGE 2 OF 4 06/2008	CONFIGURATION DRAWING

BALL SHUT-OFF

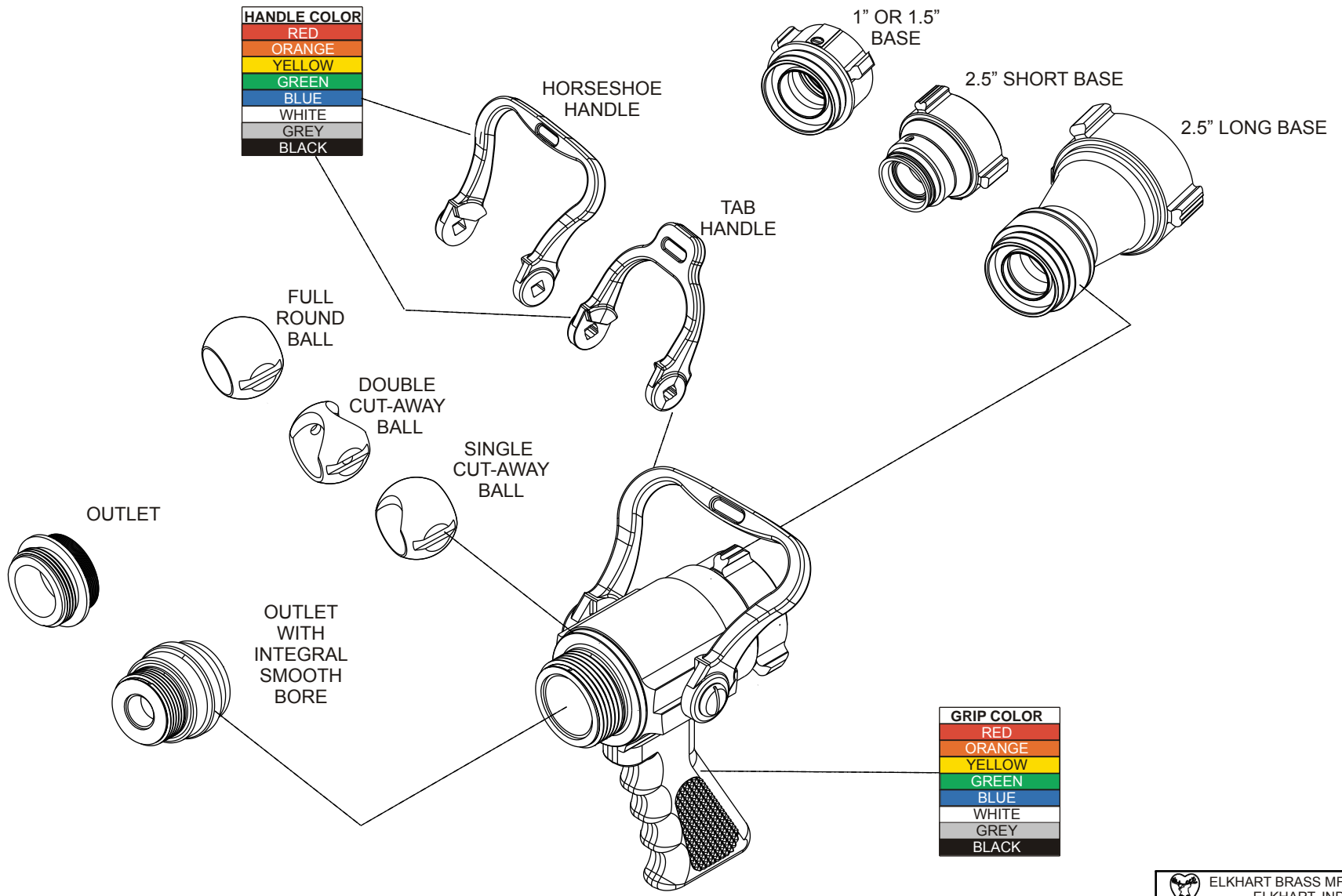

HANDLE COLOR
RED
ORANGE
YELLOW
GREEN
BLUE
WHITE
GREY
BLACK

GRIP COLOR
RED
ORANGE
YELLOW
GREEN
BLUE
WHITE
GREY
BLACK

FIGURES DEPICT GENERAL PRODUCT TYPES ONLY AND ARE NOT INTENDED TO BE INCLUSIVE OF ALL PRODUCT FEATURES.

 ELKHART BRASS MFG. CO., INC. ELKHART, INDIANA	
THIS DRAWING CONTAINS INFORMATION THAT IS PROPRIETARY TO ELKHART BRASS MFG. CO., INC. AND MAY NOT BE USED TO PRODUCE ANY PARTS, ASSEMBLIES OR PRODUCTS DESCRIBED HEREIN WITHOUT EXPRESS WRITTEN PERMISSION.	
BALL SHUT-OFF & PLAYPIPE PAGE 1 OF 3 06/2008	CONFIGURATION DRAWING

PLAYPIPE

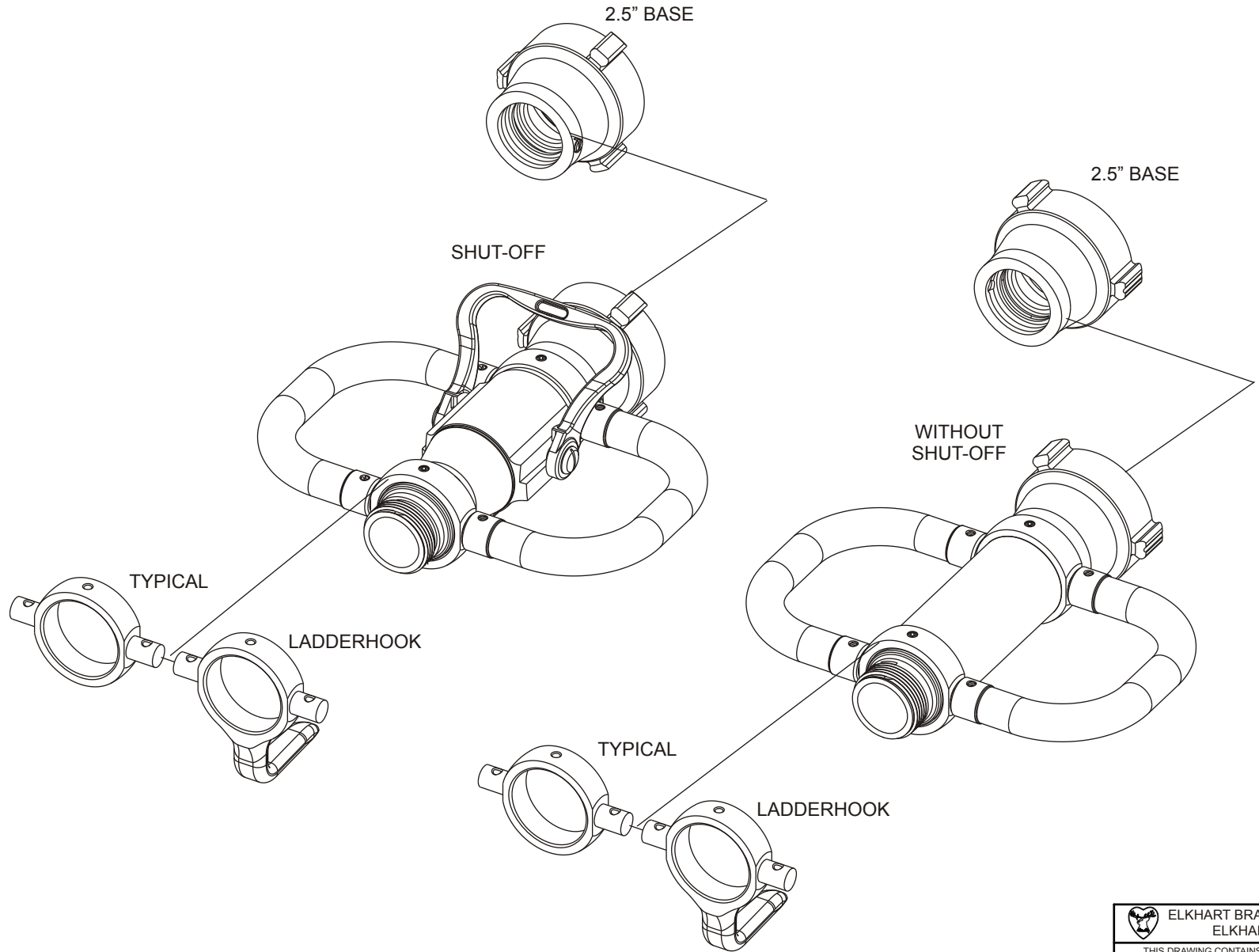

FIGURES DEPICT GENERAL PRODUCT TYPES ONLY AND ARE NOT INTENDED TO BE INCLUSIVE OF ALL PRODUCT FEATURES.

 ELKHART BRASS MFG. CO., INC. ELKHART, INDIANA	
<small>THIS DRAWING CONTAINS INFORMATION THAT IS PROPRIETARY TO ELKHART BRASS MFG. CO., INC. AND MAY NOT BE USED TO PRODUCE ANY PARTS, ASSEMBLIES OR PRODUCTS DESCRIBED HEREIN WITHOUT EXPRESS WRITTEN PERMISSION.</small>	
BALL SHUT-OFF & PLAYPIPE PAGE 2 OF 3 06/2008	CONFIGURATION 000Y 00

