

Cobra™ EXM Monitor

Efficient, high-flow, electric remote controlled water monitor (water cannon) for fire apparatus, industrial pumper, and aerial vehicles.

The COBRA™ EXM monitor is specially designed to be compact providing a greatly reduced swing radius. Unique waterway swivel joints utilize stainless steel thrust rods, and needle roller thrust bearings, for unprecedented durability in a range of applications. The COBRA™ EXM utilizes a cast vaned waterway to minimize large-scale turbulence. The monitor may be powered with 12 or 24 volts.

Several base options are available for use with the COBRA™ EXM including a 3" flange, DN80-PN16 flange, 4" flange, 3" female NPT, and 3" female BSPT. The discharge may be ordered with either a 3.5" NHT or BSPP thread. The COBRA™ EXM comes standard with permanent magnet DC gear motors but may be upgraded to high power motors. Both motor options are sealed to NEMA 4.



Cobra™ EXM Monitor

Mechanical Features:

- Sealed to NEMA 4
- 1500 GPM (5678 LPM) Flow
- Axially aligned thrust bearings
- Absolute position sensors
- Manual travel override
- Teflon impregnated, hard anodized aluminum alloy waterway
- High efficiency sealed planetary gearboxes

Control Features:

- Universal input voltage 11-27VDC
- Wired or wireless communication
- CAN bus J1939 compatible
- Single speed, two speed, or fully proportional speed control
- Programmable 3D Travel Limits, Keep-Out Zones, Travel Speeds, Stow Position, and Oscillation
- Integration water valve control
- Position display

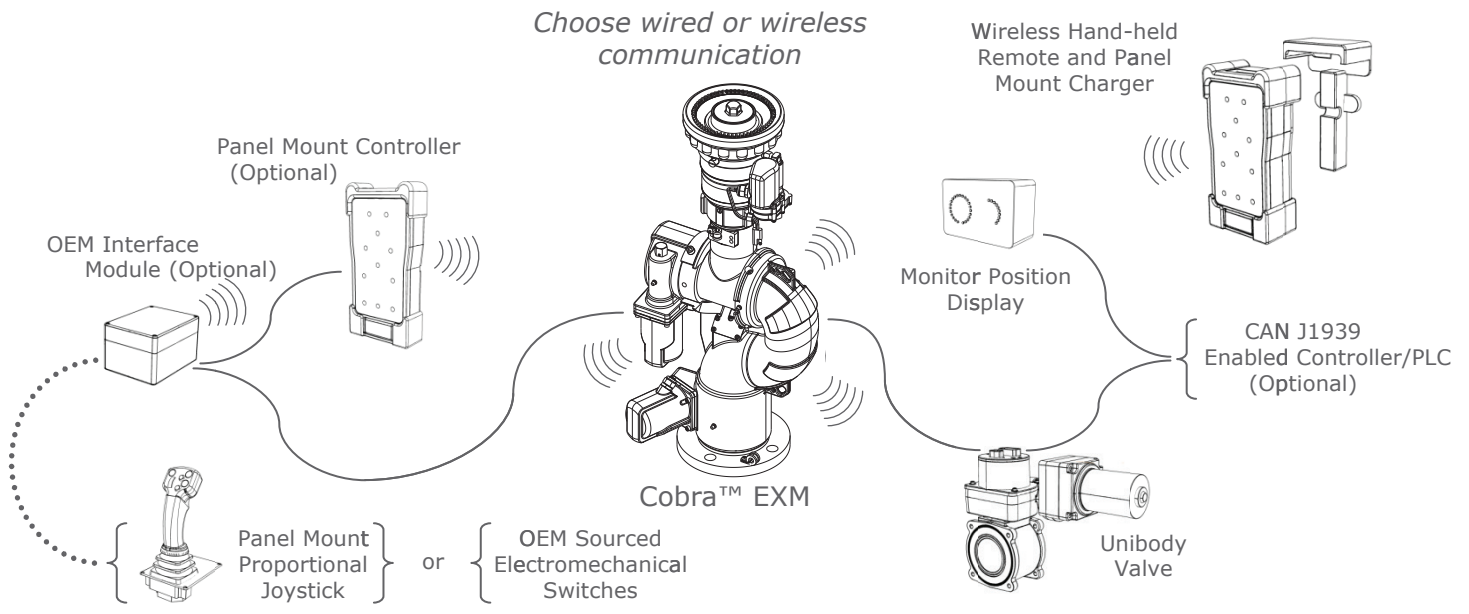

Cobra™ EXM Monitor

SPECIFICATIONS	
Model	7250
Max Flow	1500 GPM
Max Pressure	500 PSI (Limited Duty)
Inlet	3"-150# F, 4"-150# F, DN80-PN16 F, 3" NPT, 3" BSPT
Outlet	3.5" Male NHT & BSPP
Travel	V: -45° to +120° H: L175° to R175°
Control Communication	CAN bus J1939 2.4 Ghz digital radio frequency (unlicensed)
Swing Radius	6" (180°), 8" (360°)
Stow Height	16"
Weight	32 Lbs.

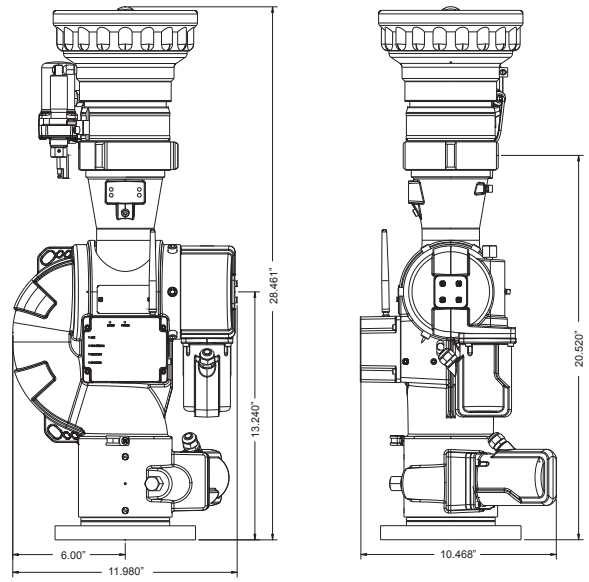

**7250 Cobra™ EXM Static Pressure Drop
(3.0" Inlet and 3.5" Outlet)**

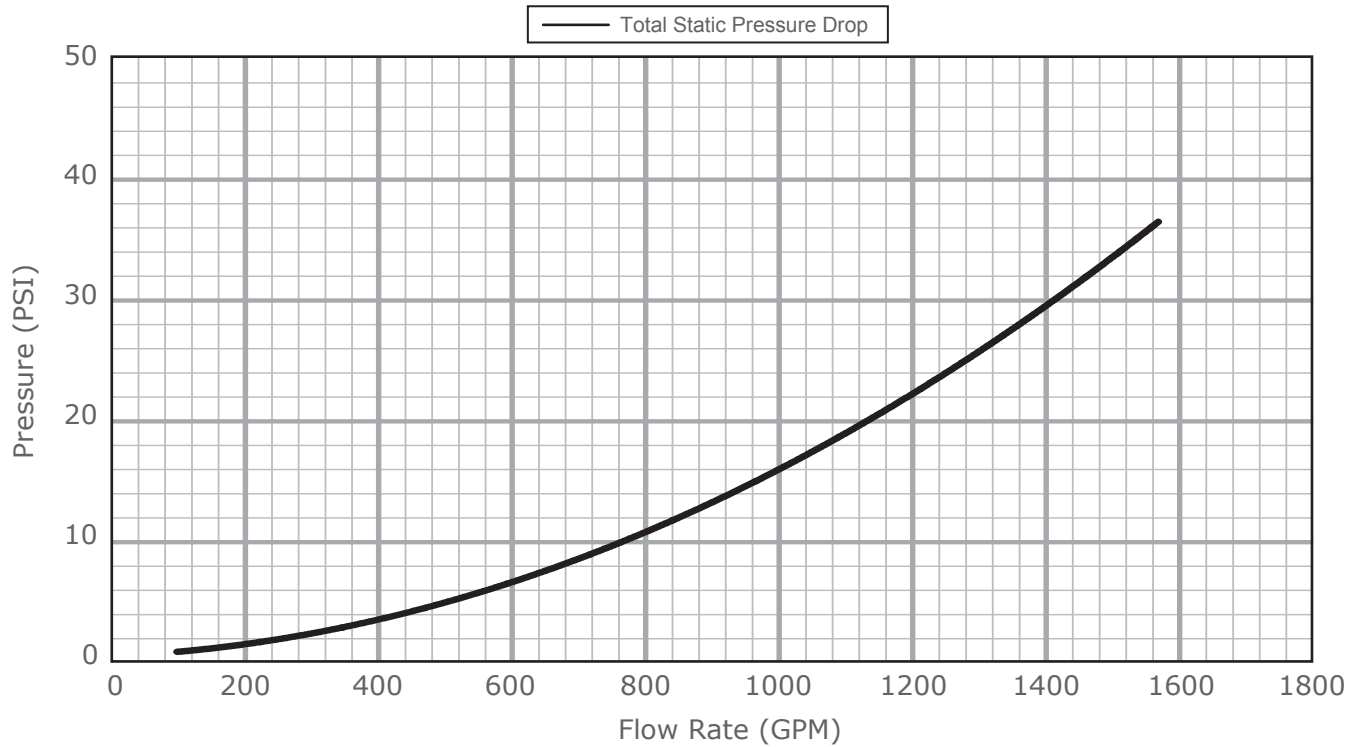

X-Stream™ Series Master Stream Nozzles

The SM1500E is an electrically actuated master stream nozzle for use with the Cobra™ EXM monitor. The X-Stream series nozzles automatically adjust to maintain an effective stream and maximum reach at variable or reduced flows. Electric actuators are completely sealed and allow precise pattern control from straight stream to wide fog.

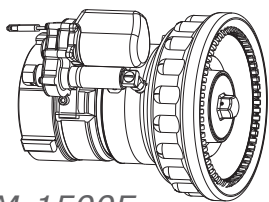

SM-1500E

SPECIFICATIONS			
Model	Inlet	Pressure PSI(BAR)	Flow Range - GPM(LPM)
SM1500E	3.5"	70 (4.83)	500-1500 (1893-5678)