

FOAM EDUCATORS



BUILT-IN

Built-In

Elkhart offers built-in foam educators for all handlines (pipe sizes of 1.5" and 2"), and the educators are compatible with most foam concentrates. The built-in educators come furnished with valves, fittings and accessories for installing permanently behind the panel in pump compartment.

Package includes:

- One (1) 240 by-pass educator
- One (1) 890-01-01-D 1.00" inline valve
- Two (2) 775-15 tee handles
- Two (2) 775-11 rod guides
- One (1) "thru the panel" metering valve with 5 settings (0%, 1/2%, 1%, 3%, and 6%)
- One (1) ball check valve
- One (1) brushed stainless steel instruction plate (with hardware)

FOAM EDUCATORS

3-4

ELKHART BRASS

**95 GPM
FOAM
SYSTEM**

**CLASS A/B
FOAM**

SEE OPERATING INSTRUCTIONS BEFORE USE
 METERING SETTINGS: 0.5, 1, 3, & 6 %
 USE WITH MATCHED (95 GPM) ELKHART NOZZLE
 MAXIMUM HOSE LAY: 1 1/2" HOSE 150-FT.
 1 3/4" HOSE 250-FT.
 WITH MAX. 10-FT. NOZZLE ELEVATION

VALVES	VALVE POSITION FOR		
	FOAM	WATER ONLY	FLUSH (3 MIN)
METERING ①	SELECT FOAM %	----	6%
WATER ②	OPEN	OPEN	OPEN
EDUCATOR BY-PASS VALVE ③	CLOSE (200 PSI)	OPEN	CLOSE (100 PSI)
FOAM ④	OPEN	CLOSE	CLOSE
FLUSH ⑤	CLOSE	CLOSE	OPEN

NPT INLET / OUTLET*	FLOW RATES GPM (LPM)			LENGTH (Inches)	PACKAGE WEIGHT (Lbs.)	MODEL NUMBER
	60 (227)	95 (360)	125 (473)			
2.0"	•			17.25	32.9	240-60P
s		•		17.25	32.9	240-95P
s			•	17.25	32.9	240-125P

KEY s = standard o = option
* Victaulic available

Typical Installation

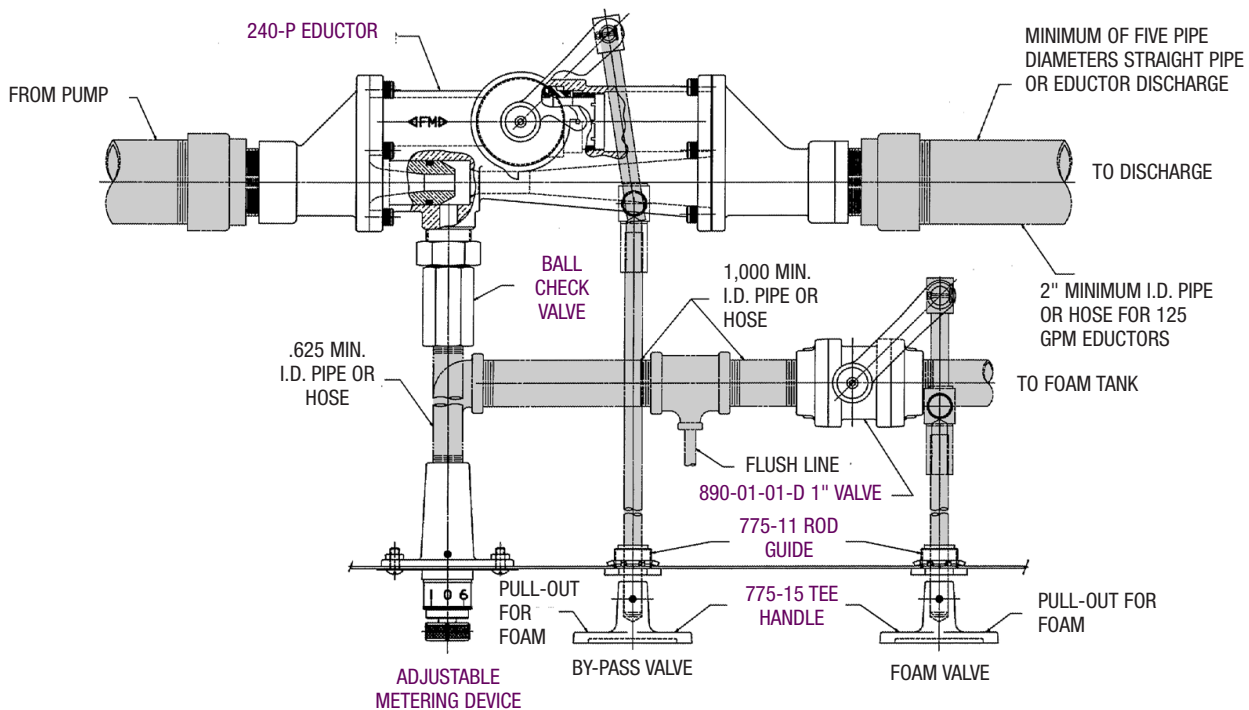

NOTE: Items listed in purple type are included in package.

Operating Pressures of Eductors

These eductors are designed to achieve rated flow with an inlet pressure of 200 psi. They will operate at lower inlet pressures, but the flow rate and percentage rate will be effected.

Checklist if eductor fails to pick up foam

Ball check stuck	Clogged nozzle
Eductor handle not pulled out	Elbow plumbed too close to inlet/outlet
Excessive friction loss between eductor and discharge outlet	Foam handle not pulled out
	Foam tank not vented
Foam tank empty	Kink in hose
Hose lay too long	Metering valve set improperly
Metering valve clogged with dry foam	Partially closed nozzle
Mismatched nozzle	Too much nozzle elevation