

5000-E Nozzle Lubrication Instructions

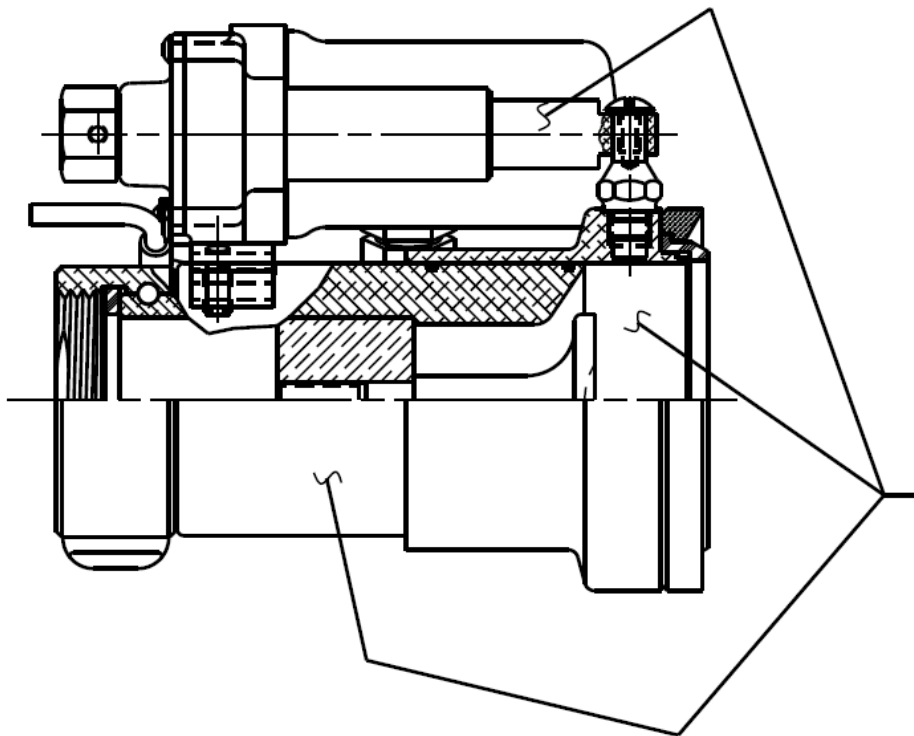

LUBRICATION TO BE PERFORMED MONTHLY OR MORE FREQUENTLY IF DICTATED BY THE ENVIRONMENT

CLEAN AND WIPE THESE O-RING SURFACES BEFORE LUBRICATING

- 1) Place nozzle in the straight stream position.
- 2) Clean o-ring surfaces with mild soap and water and wipe dry (See illustration above).
- 3) Use Dow corning #7 silicone grease to lubricate the surfaces that the Nozzle Tip o-rings move across (See illustration above). Coat these surfaces with grease while the nozzle is in the Straight Stream position (all the way forward). Run the tip back and forth through its full range of motion several times to distribute the grease. Stop the Nozzle Tip in the Wide Fog position (all the way back) and wipe off any excess grease. (The nozzle should be lubricated after every use, and as needed between uses, to maintain a coating of grease on the o-ring surfaces.)
- 4) Run the nozzle through its entire range of motion at least once a week.
- 5) Store the nozzle in the Wide Fog position to limit exposure of the grease covered o-ring surfaces to the elements and ANY contaminants that may come into contact with the grease.

98275020 (Rev-REL)