



# ELKHART BRASS MFG. CO., INC.

1302 WEST BEARDSLEY AVENUE • P.O. BOX 1127 • ELKHART IN 46515 • (574) 295-8330 • FAX (574) 293-9914

## Brief Installation Instructions For Bumper Replacement

For Detailed Description of Instructions See Detailed Installation Instructions

### All Nozzles Except SM-3 Series and 4000-01 Series

**Step 1:** Remove nozzle tip from nozzle body and cut existing bumper off of nozzle tip

**Step 2:** See Table 1 and assemble parts as shown in Figure 1.

**Step 3:** Fix bottom hex nuts with a vice or wrench. Turn top hex nut to force bumper down on tip.

**Step 4:** Disassemble bumper replacement kit and reattach nozzle tip to nozzle body.

Table 1

NOZZLE TYPE	EXPANSION CONE	PUSH TUBE	TOOTH GUARD SIDE UP	DRIVE PLATE SIDE UP
SM-3 SERIES 4000-01 SERIES	N/A	N/A	1	1
SM-10 & SM-20 SERIES 4000-10 SERIES	SMALL	SMALL	1	2
SM-30 SERIES 4000-20 SERIES	LARGE	LARGE	2	1
4014 4000-20LP	SMALL	SMALL	2	2

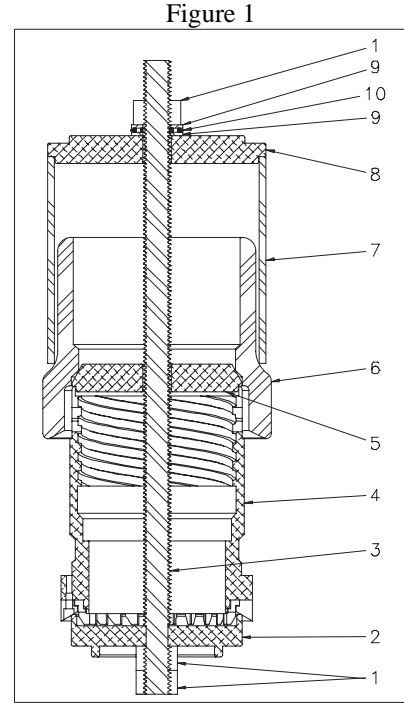

Bumper Replacement Assembly

### Only SM-3 Series and 4000-01 Series

**Step 1:** Remove nozzle tip from nozzle body and cut existing bumper off of nozzle tip

**Step 2:** Push bumper over tip of nozzle by hand.

**Step 3:** See Table 1 and assemble parts as shown in Figure 2.

**Step 4:** Fix bottom hex nuts with a vice or wrench. Turn top hex nut to force bumper down on tip.

**Step 5:** Disassemble bumper replacement kit and reattach nozzle tip to nozzle body.

Table 2 – Bill of Materials

INDEX NO.	DESCRIPTION	QUANTITY PER UNIT
1	Hex Nut	3
2	Tooth Guard	1
3	Threaded Rod	1
4	Nozzle Tip	1
5	Expansion Cone	2
6	Bumper	1
7	Push Tube	2
8	Drive Plate	1
9	Thrust Washer	2
10	Thrust Bearing	1

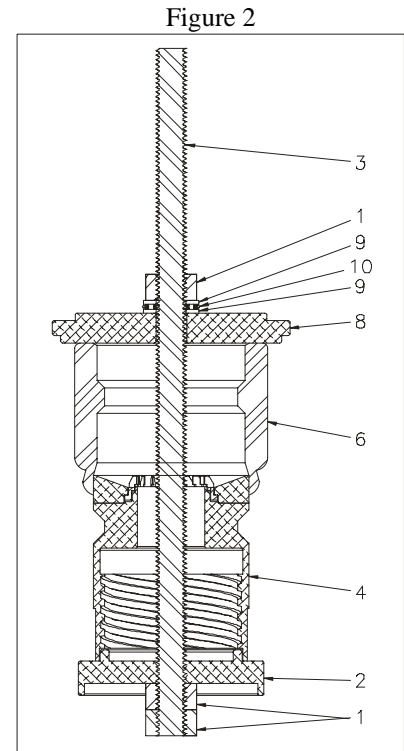

SM-3 Series and 4000-01 Series Bumper Replacement Assembly



# ELKHART BRASS MFG. CO., INC.

1302 WEST BEARDSLEY AVENUE • P.O. BOX 1127 • ELKHART IN 46515 • (574) 295-8330 • FAX (574) 293-9914

## Arbor Press or Drill Press Instruction For All Nozzles Except SM-3 Series and 4000-01 Series

Step 1: Remove nozzle tip from nozzle body and cut existing bumper off of nozzle tip

Step 2: See Table 1 and assemble parts as shown in Figure 3.

Step 3: Place assembled parts vertically into Arbor Press or Drill Press and add force to drive plate to force bumper down on tip.

Step 4: Disassemble bumper replacement kit and reattach nozzle tip to nozzle body.

Figure 3

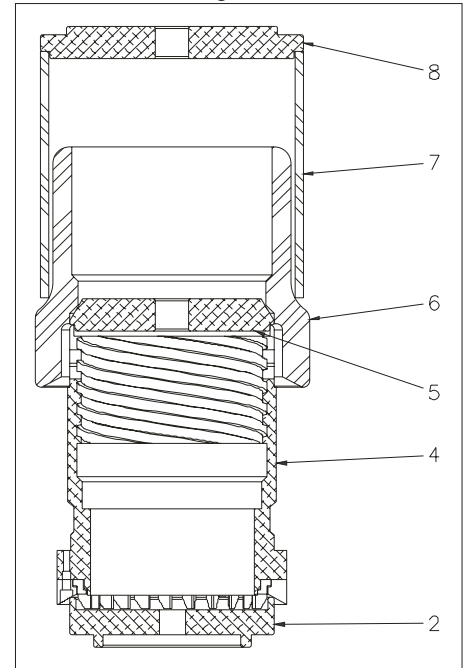

Arbor Press Bumper Replacement Assembly

## Arbor Press or Drill Press Instructions For Only SM-3 Series and 4000-01 Series

Step 1: Remove nozzle tip from nozzle body and cut existing bumper off of nozzle tip

Step 2: Push bumper over tip of nozzle by hand.

Step 3: See Table 1 and assemble parts as shown in Figure 4.

Step 4: Place assembled parts vertically into Arbor Press or Drill Press and add force to drive plate to force bumper down on tip.

Step 5: Disassemble bumper replacement kit and reattach nozzle tip to nozzle body.

Figure 4

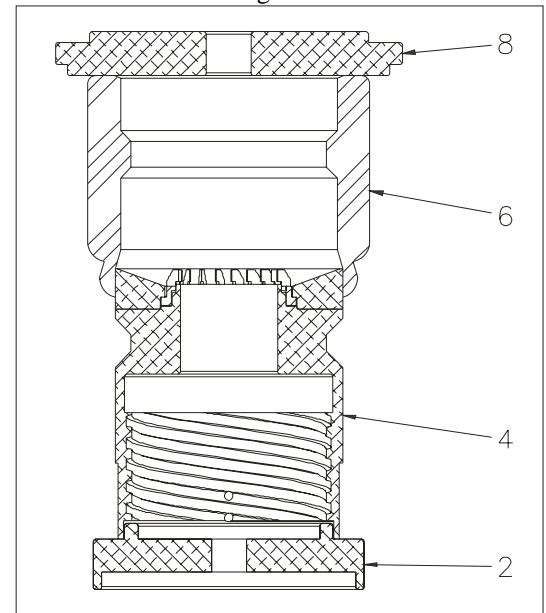

SM-3 Series and 4000-01 Series  
Arbor Press Bumper Replacement Assembly