



Detailed Installation Instructions For Bumper Replacement

All Nozzles Except SM-3 Series and 4000-01 Series

Step 1: Locate and remove the two indicator sleeve screws by using a #10 Torx bit as shown in Figure 1. After removing the screws, turn the tip of the nozzle counter-clockwise until it threads off of the nozzle body. Remove the bumper by cutting it off with a utility knife. **Caution – Secure nozzle tip before cutting off bumper.**

Step 2: See Table 1 to determine which side of the tooth guard should be facing up for the nozzle being repaired. Thread the tooth guard and two hex nuts onto the threaded rod as shown in Figure 2. Slide the expansion cone (also determined from Table 1) down onto the opposite end of the threaded rod until it rests into the back side of the nozzle tip as shown in Figure 2.

Step 3: Place the replacement bumper on the expansion cone with the threaded rod through the center of it. **A soap and water solution should be applied to the inside of the bumper as a lubricant. Be sure to line up the slots on the inside of the bumper with the screws protruding from the front of the nozzle tip.** Determine the correct push tube to be used from Table 1 and slide it down over the bumper. Use Table 1 to determine which side of the drive plate should be facing up and slide it down on the threaded rod until it comes to rest on top of the push tube. Slide a thrust washer, thrust bearing, and another thrust washer onto the end of the threaded rod until they rest on the drive plate. Thread the remaining hex nut down onto the threaded rod until it rests on the top thrust washer.

Step 4: Hold the bottom set of hex nuts stationary by using either a vice or a wrench. Turn the top hex nut clockwise with a wrench to force the bumper down until it is flush with the end of the nozzle tip. Turn the top hex nut counter-clockwise until it is off the threaded rod. Pull the bumper kit apart and reattach the nozzle tip to the nozzle body. Do not forget to re-insert indicator sleeve screws.

Figure 1

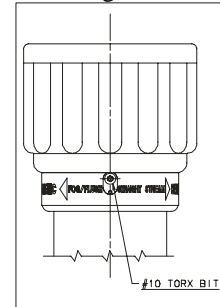

Location of Indicator Sleeve Screws

Figure 2

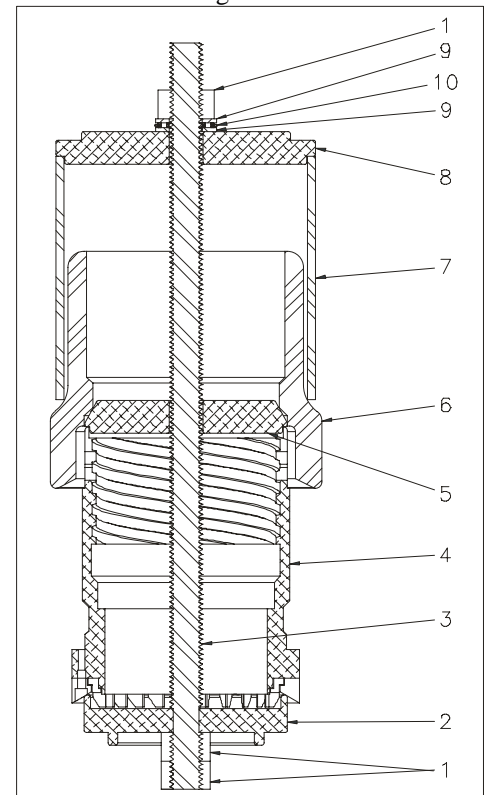

Bumper Replacement Assembly Configuration

Table 1

NOZZLE TYPE	EXPANSION CONE	PUSH TUBE	TOOTH GUARD SIDE UP	DRIVE PLATE SIDE UP
SM-3 SERIES 4000-01 SERIES	N/A	N/A	1	1
SM-10 & SM-20 SERIES 4000-10 SERIES	SMALL	SMALL	1	2
SM-30 SERIES 4000-20 SERIES	LARGE	LARGE	2	1
4014 4000-20LP	SMALL	SMALL	2	2

INDEX NO.	DESCRIPTION	QUANTITY PER UNIT
1	Hex Nut	3
2	Tooth Guard	1
3	Threaded Rod	1
4	Nozzle Tip	1
5	Expansion Cone	2
6	Bumper	1
7	Push Tube	2
8	Drive Plate	1
9	Thrust Washer	2
10	Thrust Bearing	1



Bumper Replacement Instructions (Only SM-3 Series and 4000-01 Series)

Step 1: Complete Step 1 from the previous instruction set.

Step 2: Press the bumper onto the front of the tip by hand as shown in Figure 3. **In order to assist in this process a soap and water solution should be applied to the inside of the bumper.** See Table 1 to determine which side of the tooth guard should be facing up for the nozzle being repaired. Thread the tooth guard and two hex nuts onto the threaded rod as shown in Figure 4. Make sure the front of the nozzle is facing up as shown. Slide the drive plate on the threaded rod until it rests on the top of the bumper. Slide a thrust washer, thrust bearing, and another thrust washer onto the end of the threaded rod until they rest on the drive plate. Thread the remaining hex nut down onto the threaded rod until it rests on the top thrust washer.

Step 3: Hold the bottom set of hex nuts stationary by using either a vice or a wrench. Turn the top hex nut clockwise with a wrench to force the bumper down until it is flush with the end of the nozzle tip. Turn the top hex nut counter-clockwise until it is off the threaded rod. Pull the bumper kit apart and re-assembled the nozzle tip to the nozzle body.

Bumper Replacement Instructions With Arbor Press or Drill Press

The installation of a new bumper can be alternatively done with the aid of an Arbor Press or a Drill Press. With this type of installation the threaded rod, hex nuts, thrust washers, and thrust bearing are not required. The assembly is put together the same as the previous instructions indicate minus these parts. The assembly, shown in Figure 5, is then placed vertically into the available press and force from the press is applied to the drive plate. The force should be applied until the bumper becomes flush with the tip of the nozzle. **The soap and water solution should still be applied to the inside of the bumper for lubrication.** After this is done the kit can be taken apart and the tip re-assembled to the nozzle body. For the assembly of a bumper to a nozzle tip from the SM-3 Series or 4000-01 Series the configuration is the same as Figure 4 minus the threaded rod, hex nuts, thrust washers, and thrust bearing.

Figure 3

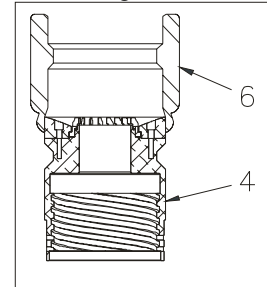

Bumper Pressed On Tip By Hand

Figure 4

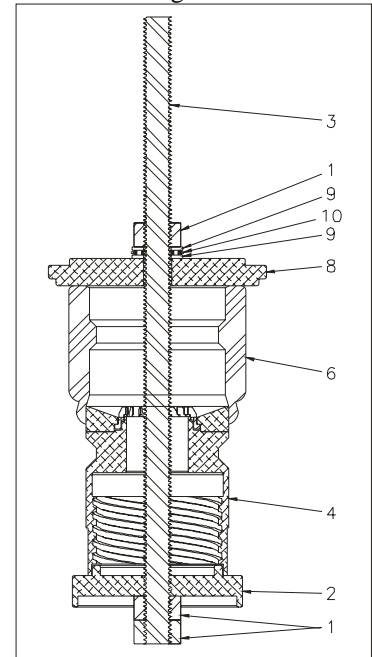

SM-3 or 4000-01 Series Assembly Configuration

Figure 5

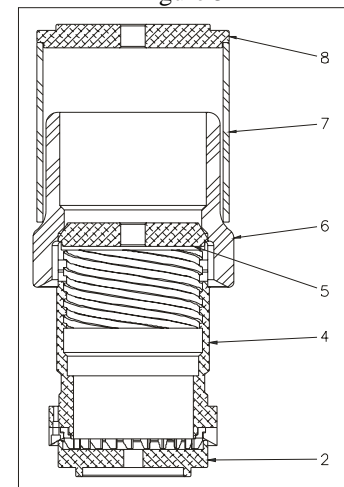

Arbor Press or Drill Press Assembly