

Universal Seal Replacement Kit

For Elkhart Brass and Akron Brass Apparatus Valves

Part Number	Fits Elkhart Brass Unibody Valve Series	Fits Akron Brass Series
65476000	EB15/EB20	8620/8820 7620/7820
65478000	EB25	8625/8825 7625/7825
65480000	EB30/EB35	8630/8830/8635/8835 7630/7830/7635/7835
65482000	EB40	8840

This service kit includes the parts required to replace the valve seat, the seat retaining ring O-rings and the adapter seals of either an Elkhart Brass Unibody series valve or an Akron Brass 8800 series valve.



ELKHART BRASS MFG. CO., INC.
1302 West Beardsley Avenue • Elkhart, IN 46514
(800) 346-0250 • (574) 295-8330
www.unibodyvalve.com

4" Valve Detail – Akron and Elkhart

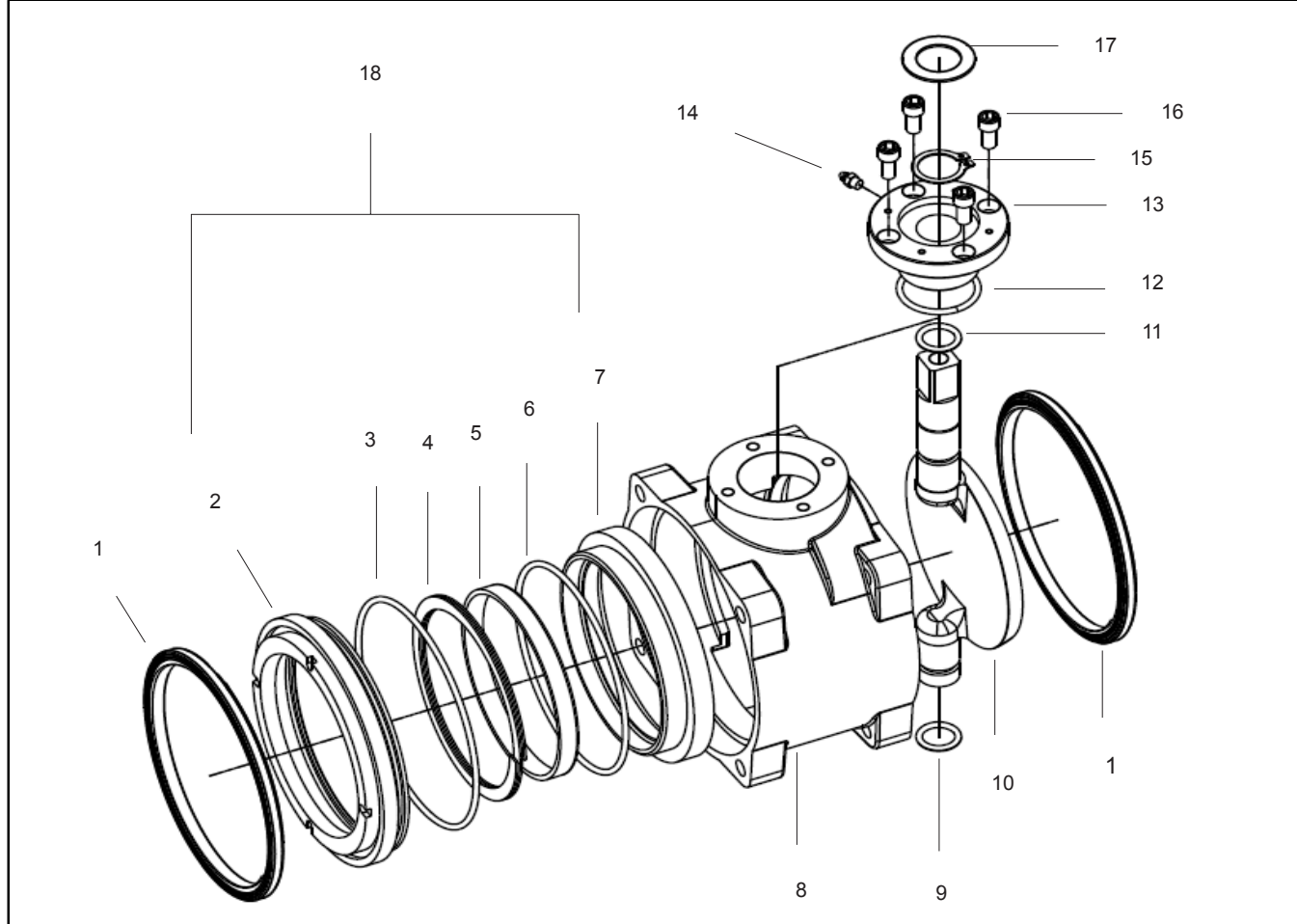

ITEM	DESCRIPTION	ITEM	DESCRIPTION
1	Adapter Seal	10	Flat Ball
2	Retaining Ring	11	O-Ring
3	O-Ring	12	O-Ring
4	Seat Spring	13	Gear Case Adapter
5	Support Ring	14	Grease Fitting
6	O-Ring	15	Retaining Ring
7	Seat	16	1/4 - 20 x 5/8 SHCS (4)
8	Body	17	Actuator Washer
9	O-Ring	18	Seat Assembly

I. DISASSEMBLY

1. Turn the valve to the closed position.
2. If the valve can be rotated out of line, remove three pairs of adapter bolts and loosen the fourth pair. Swing the valve out of the line. If the valve cannot be rotated out of line, remove all eight adapter bolts and take the valve out completely.

NOTE: 4" Valves are directional. Note the orientation of the arrow on the side of the valve body indicating flow direction.

3. Remove and discard both adapter seals (1).
4. Partially open the valve to allow access to the seat assembly (18).
5. Pull the entire seat assembly (18) out from the valve body.
6. Discard the seat (7), retaining ring inner O-ring(6) and retaining ring outer O-ring (3).

II. INSPECTION AND CLEAN-UP

1. Use a 10" or larger flat file to clean up the flat surface of the adapters and mating surfaces of the valve body. Remove any paint, corrosion or raised lip around the bolt holes.
2. Inspect the condition of the flat ball for burrs, nicks and sharp edges caused by debris. If found, carefully use fine emory paper to remove any condition which might cut the valve seat or otherwise impair sealing.

CAUTION: Completely remove any grit or debris from the valve body before assembly.

III. REASSEMBLY

NOTE: Lubricate O-rings with Parker O-Ring Lube or equivalent petroleum-based lubricant.

1. Install the new inner O-ring (6) and outer O-ring (3) on the retaining ring (2).
2. Reinsert the seat spring (4) into the cavity of the retaining ring (2).
3. Insert the seat support ring (5) into the new seat (7) with the chamfered edge to the inside of the seat.
4. Insert seat into the seat retaining ring (2).
5. Replace the entire assembly (18) into the valve body.
6. Insert the two new adapter seals (1) into the valve body.
7. Slide valve back into waterway.

NOTE: 4" valves are directional. Note the orientation of the arrow on the side of the valve body indicating flow direction.

CAUTION: The ball must be in the open position before the adapter bolts are tightened.

8. Tighten the adapter bolts evenly in an X pattern using 60-70 ft-lbs torque. **DO NOT OVERTIGHTEN.**

MAINTENANCE INSTRUCTIONS

Do not lubricate the ball or seats. Lubricants can collect dirt and grit which may cause excessive wear. Occasionally, flow water through all valves to clear dirt and debris.

OPERATING INSTRUCTIONS

Always open and close valves slowly.
Do not exceed 500 psi.

DISCLAIMER: Any reference herein to other manufacturers' names and/or their trademarks is used only for comparison purposes or to indicate compatibility and is not in any way intended to indicate an association or affiliation with or sponsorship or approval by that manufacturer.