

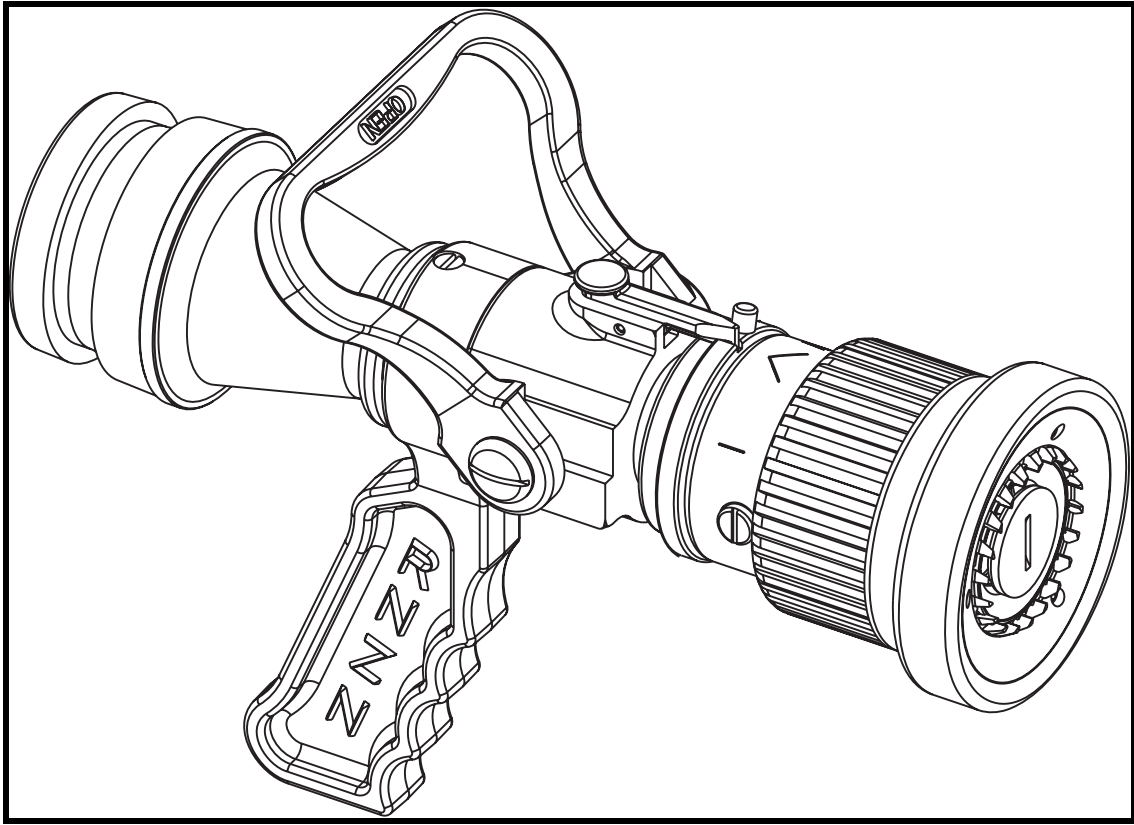

ELKHART BRASS MFG. CO., INC.

1302 WEST BEARDSLEY AVENUE • P.O. BOX 1127 • ELKHART IN 46515 • (574) 295-8330 • FAX (574) 293-9914

Operating and Maintenance Instructions



SFL-BG (RNZN)

Combination Type Nozzle
With Detent At Narrow Fog
Lloyd's Register Approved

Table Of Contents

I	Product Safety.....	1
II	Nozzle Operation.....	2
III	Maintenance.....	3
IV	Assembly Drawing.....	4

Product Safety



Important:

Before installing and operating this equipment, read & study this manual thoroughly. Proper installation is essential to safe operation. In addition, the following points should be adhered to in order to ensure the safety of equipment and personnel:

- All personnel who may be expected to use this equipment must be thoroughly trained in its safe and proper use.
- Before flowing water from this device, check that all personnel are out of the stream path. Also, check to make sure stream direction will not cause avoidable property damage.
- Become thoroughly familiar with the hydraulic characteristics of this equipment, and the pumping system used to supply it. To produce effective fire streams operating personnel must be properly trained.
- Care should be taken when opening and closing any ball shutoff. Rapid closure and/or opening may cause “water hammer” or pressure surge which could cause injury or damage to equipment.

Nozzle Operation

Flow Capabilities

This nozzle has been designed to exhibit the following flow characteristics:



- Maximum Working Flow 95 GPM (360 LPM) at a Maximum Working Pressure of 100 PSI (6.9 BAR)

Ball Shutoff

This nozzle has been equipped with a ball shutoff. The nozzle can be shut off by pushing the horseshoe handle forward, away from the user. In order to open the shutoff, the handle should be pulled back toward the user. These positions are indicated by CLOSED and OPEN lettering on the horseshoe handle. **It is very important to open and close the shutoff slowly to avoid a water hammer effect.**

Pattern Adjustment

The total tip rotation of this nozzle is 306 degrees and can be adjusted by the following steps:

- A fog pattern can be achieved by rotating the nozzle tip to the left or counter-clockwise. If the nozzle tip is rotated into this position the locking lever will be pointed to the  marking on the nozzle tip.
- A straight stream or jet pattern can be achieved by rotating the nozzle tip to the right or clockwise. If the nozzle tip is rotated into this position the locking lever will be pointed at the  marking on the nozzle tip.
- A narrow fog pattern can be achieved by stopping the rotation of the nozzle tip at the detent in between the wide fog and straight stream positions. The locking lever will be pointed at the  marking on the nozzle tip as a visual indication of this position. This position is characterized by a 45 degree fog pattern.

Flushing The Nozzle

This nozzle has been equipped with a flush position for removing small debris from the water supply that may become trapped in the nozzle. This debris may cause poor stream quality and reduced water flow capabilities. If this occurs the nozzle needs to be flushed. The nozzle can be flushed by following these steps:

- Press the locking lever down until the front end rises out of the gallonage slot. Rotate the center barrel to the left or counter-clockwise until the locking lever is pointed toward the FLUSH indication.
- After flushing the nozzle, be sure to rotate the center barrel back to the right or clockwise until the locking lever is returned to the gallonage slot.

The nozzle should be flushed after each use to ensure that debris does not built up inside the nozzle. This flushing method should also be used after flowing foam through the nozzle. If the debris is too large to pass using this method, it may be necessary to shut down the hose line and remove the nozzle. Large debris can then be removed from the base of the nozzle or from around the stem head.

Maintenance

Weekly visual inspections and monthly operational inspections should be exercised in order to ensure reliable operation. These inspections may be done on a daily basis depending on the needs of the user. All nozzles should be flow tested before entering any hazardous area to ensure equipment is operating properly.

If the nozzle tip is not functioning correctly, it may need to be re-greased. This can be done by removing the detent screws (19), then removing the tip (20) from the nozzle. These parts can be seen in the following assembly drawing. Clean the acme threads with a rag then generously apply silicone grease (Climax #66111) to the acme threads. Reassemble the nozzle tip to the center barrel and clean excess grease from the nozzle.

If the shut-off handle begins to operate too easily, the adjustable seat (7) may need to be tightened. This can be done without disassembling the entire nozzle. Remove the set screw (24) from the nozzle body. After this is done the pistol grip (28) can be removed from the nozzle assembly. These parts can be seen in the following assembly drawing. Use an Elkhart Brass Seat Wrench (P/N 71251000) to adjust the seat until the desired tightness is achieved. Reassemble the nozzle. Be sure to apply thread locker (Loctite #242 or equivalent) to the set screw before reassembling.

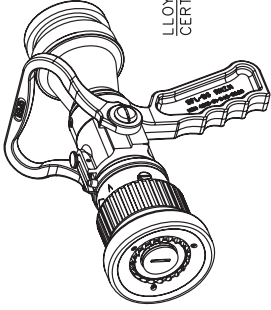

LLOYD'S REGISTER APPROVAL
CERTIFICATE # SAS F070006

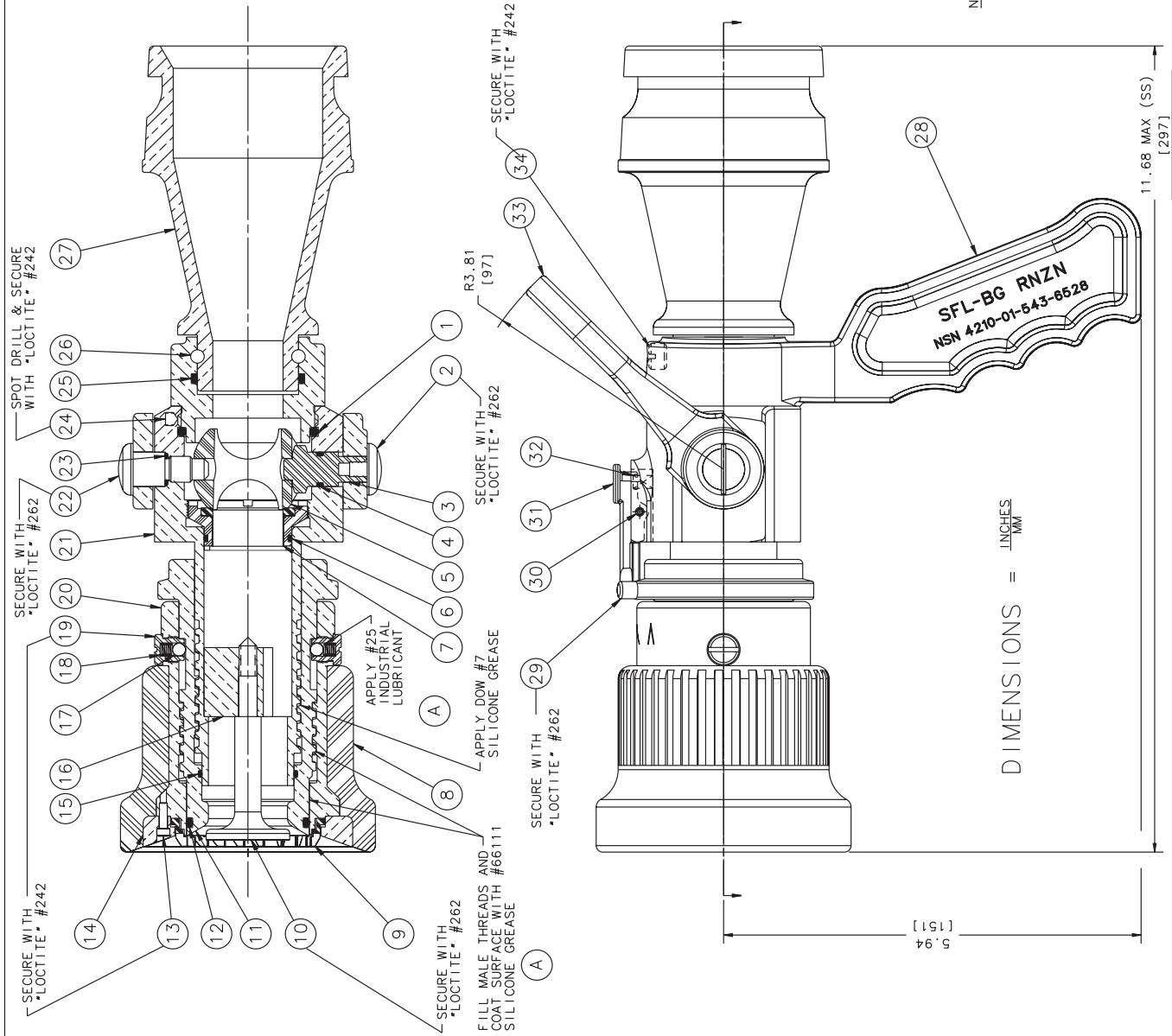

NO.	PART NO.	PART NAME	REQ.
34	61248000	SCREW-SET (BRASS) 0.375-24 X 0.250-LG. SLT. HD.	1
33	36085000	HANDLE-HORSHU (DOUBLE STOP) CA 95300	1
32	61762000	SPRING-COIL	1
31	44064101	LEVER-LOCKING	1
30	51253000	PIN-ROLL (BRONZE) 0.125-D X 0.562-LG X 0.028-THK.	1
29	52110001	PIN-SOLID	1
28	33827001	PISTOL GRIP (SB)	1
27	17396001	BASE-F/S 2.5 (65MM) B. I.	1
26	15016000	BALLS 0.187 DIA BR.	23
25	57336000	RING-O (#AS-568-127) 1.391-ID X 0.250-LG. S/S	1
24	63685000	SCREW-SET CONE PKG S/S TYPE #302	1
23	57348000	RING-O (#AS-568-010) 0.239-ID X 0.070-C/S	1
22	63708000	SCREW-PIVOT	1
21	17116002	BODY-NOZZLE (SB)	1
20	66416001	TIP-NOZZLE	1
19	65058000	SCREW - DETENT (SS) 0.375 - 24 THDS	2
18	65703000	SPRING - COIL (SS) 0.180 O.D. X 0.310 LG	2
17	15018000	BALLS 0.187 DIA SS	2
16	63408001	BASE (WEB) STEM	1
15	57392000	RING-O (#AS-568-027) 1.391-ID X 0.070-C/S	1
14	57627004	RING - RETAINER	1
13	63780000	SCREW-CAP (#316 S/S) 4-40 X 0.375-LG. S/S HD	3
12	57398000	RUBBER #316 1.487-ID X 0.103-C/S	1
11	18110001	BARREL-CENTER(95 GPM)	1
10	62084001	STEM-NOZZLE	1
9	58870000	RING-TEETH(SPINNING)	1
8	33643000	GRIP-HAND	1
7	61357000	SEAL-ADJUSTABLE	1
6	57327000	RING-O (#AS-568-024) 1.114-ID X 0.070-C/S	1
5	15076000	BALL-VALVE	1
4	57298000	RING-O (#AS-568-012) 0.364-ID X 0.070-C/S	1
3	63755000	SHAFT-ACTUATOR (SO)	1
2	61286000	SCREW-SHAFT	1
1	57309000	RING-O (#AS-568-224) 1.734-ID X 0.139-C/S	1

NOZZLE WEIGHT
11 LBS
4.99 KG

NO.	PART NO.	PART NAME	REQ.
ELKHART BRASS MFG. CO., INC. ELKHART, INDIANA			
SFL-BG SELECT-O-FLOW NOZZLE, DETENT AT NARROW FOG, 95 GPM			
SCALE	1:1	DATE	10/02/06
DRG BY	KAS	CHK BY	
APP'D BY		DATE	
STANDARD TOLERANCES: 3 PLACE DEC - 1.010 2 PLACE DEC - 1.010 UNLESS OTHERWISE SPECIFIED DIMENSIONS - 10-32-84			
SDRC REMOVE ALL BURS AND SHARP CORNERS UNLESS OTHERWISE SPECIFIED DO NOT SCALE PRINT			